

Fusion One

Housekeeping Chemical Dispensing System

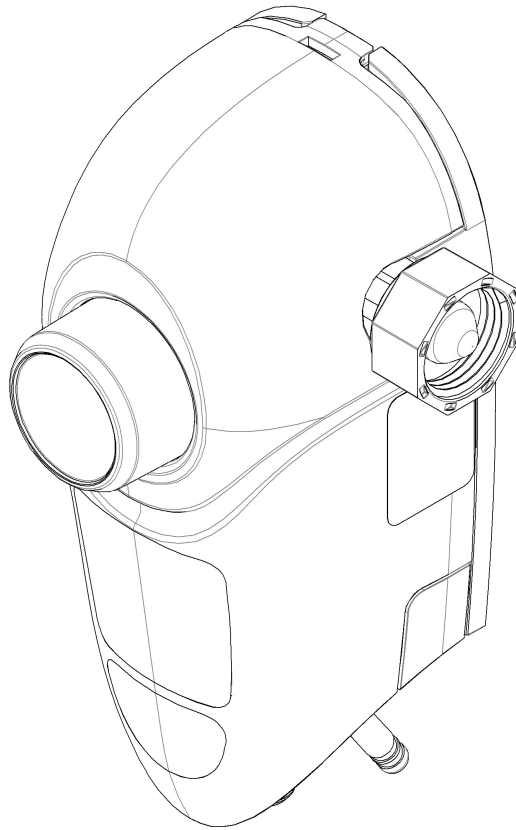

Installation and Setup Guide

Fusion One accurately blends proportioned chemical with water for cleaning, sanitizing or `needs. The dispensing system uses a pilot drive water valve designed for easy maintenance. Fusion One is engineered with 1055 approved back flow protect using DEMA's Air Gap or Action Gap proportioning system.

Warnings



All installations must conform to local plumbing codes and use approved backflow prevention devices. A pressure indicating tee is to be installed with existing faucets according to local plumbing codes in the state of Wisconsin and any other state that requires the use of a pressure indicating tee.



ALWAYS WEAR PROTECTIVE CLOTHING AND EYEWEAR WHEN WORKING WITH CHEMICAL PRODUCTS.

Installation and Servicing



WARNING: INSTALLATION OF DEMA PRODUCTS MUST MEET ALL APPLICABLE PLUMBING CODES AND REGULATIONS ESTABLISHED BY NATIONAL, CITY, COUNTY, PARISH, PROVINCIAL OR OTHER AGENCIES. IT IS POSSIBLE THAT PLUMBING CODES AND REGULATIONS REQUIRE THAT A CERTIFIED INSTALLATION CONTRACTOR OR ENGINEER PERFORM THE PLUMBING INSTALLATION.

1. Locate where to install the Fusion One dispenser.
Keep the following in mind
 - a. Mount near or over a mop sink.
 - b. Best access to water hookup.
2. Remove the Fusion One cover by pressing the plastic tabs on the side of the unit and swing the bottom away from the mounting bracket.
3. Determine if the water supply connection should be on the right or left-hand side of the dispenser.
 - a. The entire valve and proportioner assembly can be removed from the mounting bracket (see illustration on this page).
 - b. The water supply connection can be moved to either side by removing the plastic, orange retainer clips, the plug and the water connection fitting. Then replace the retainer clips.

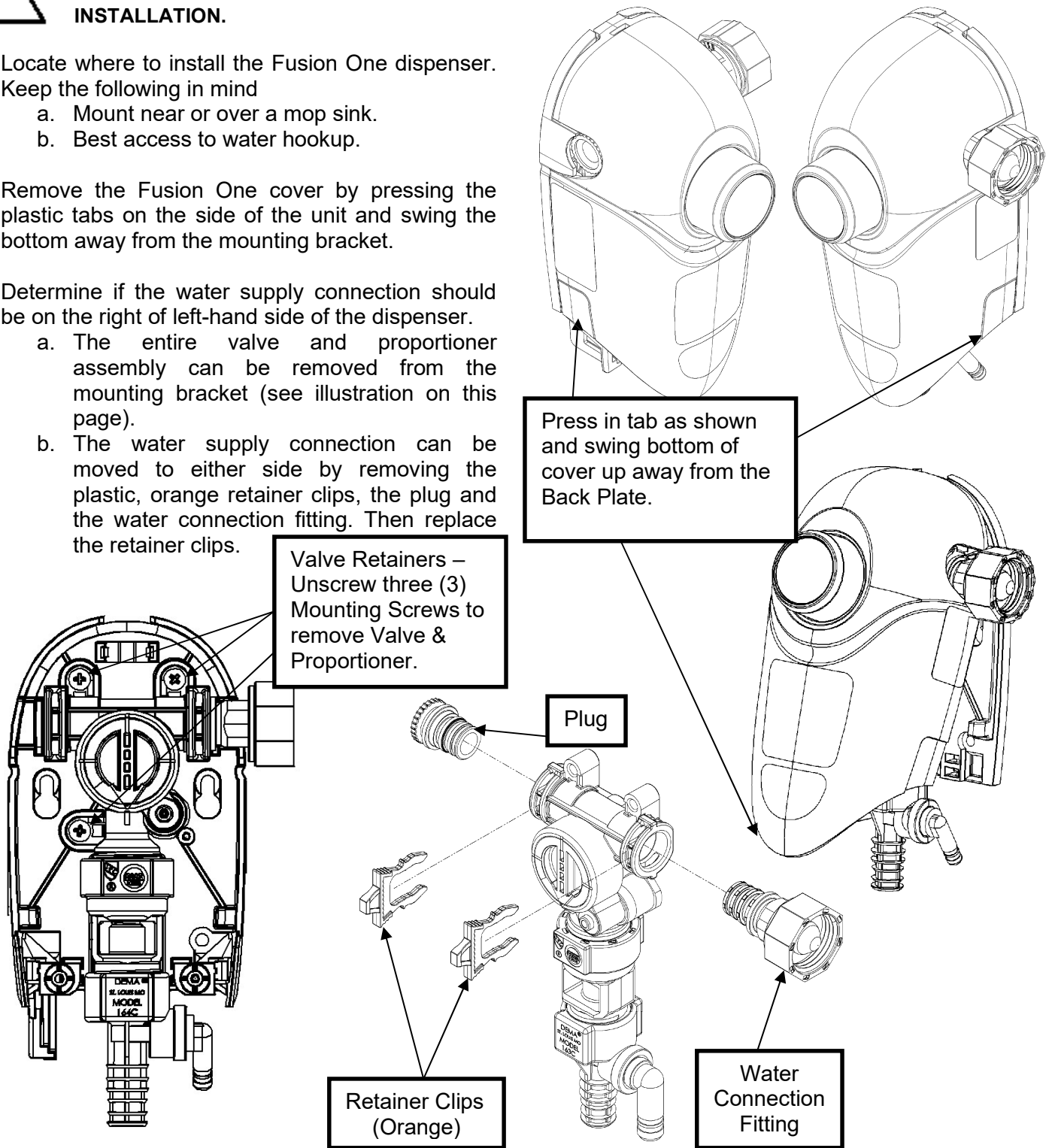

Installation and Servicing Continued...

4. Locate the 2 key shaped mounting holes in the back plate. Mount the Fusion One using the 2 mounting screws and anchors that are included in the installation kit; with the aid of the integrated bubble level.
5. Install the desired metering tip by threading tip into the proportioner chemical pick-up elbow.
6. Cut the chemical supply tube to the length allows the foot valve to rest on the bottom of the chemical container. Slide the ceramic weight onto the chemical supply tube until it is against the foot valve. This will keep the foot valve at the bottom of the chemical container.
 - a. Note: Chemical containers cannot be greater than 6 feet (1.8M) below the Fusion One dispenser.
7. Install the Fusion One cover by positioning the top of the cover near the top of dispenser back plate and push the cover back over the valve assembly until the tab latches on side of the unit.
8. Connect the water line to the inlet of the Fusion One.
 - a. Note: The water pressure must be between 20psi and 95psi. Optimum chemical induction occurs between 30psi – 60psi.
 - b. The water inlet options for the Fusion One are:
 - i. Garden Hose (female)
 - ii. 3/8" Brass Compression Fitting (suitable for 3/8" OD soft copper water line)
 - iii. 3/8" John Guest Push-on Water Fitting (suitable for 3/8" OD soft copper or LDPE tubing)
 - iv. 3/8" Brass Barb Water Fitting (suitable for 3/8" LDPE tubing)
 - c. The Fusion One can be used in conjunction with a pressure indicating tee, P/N 68.6.QD2.

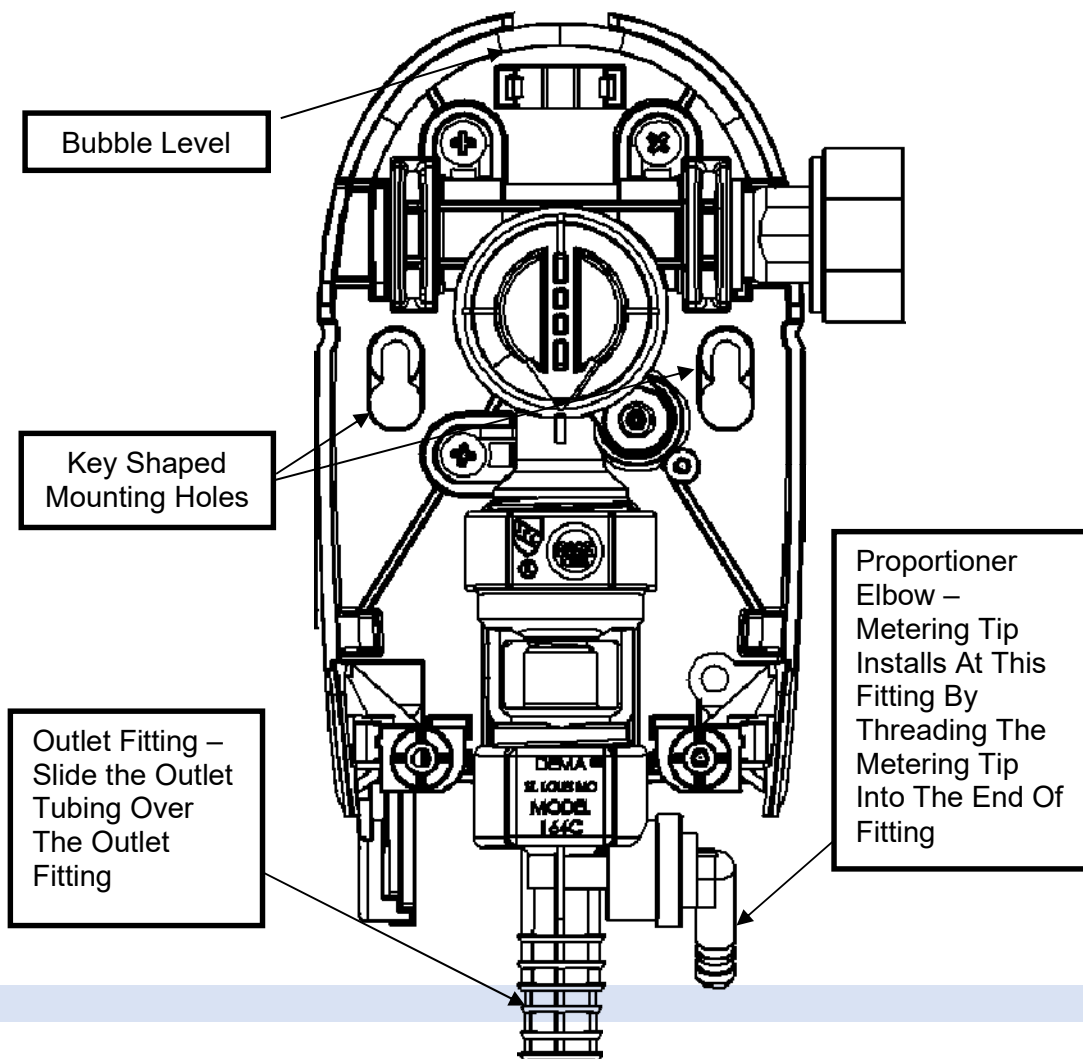

Installation and Servicing Continued...

9: Removal of Button Tab to engage Locking Activation feature (for 4GPM Proportioners).

Step 1: Remove Fusion One cover (see #2 above).

Step 2: Break off tab with pliers.

Fusion Cover – Rear View

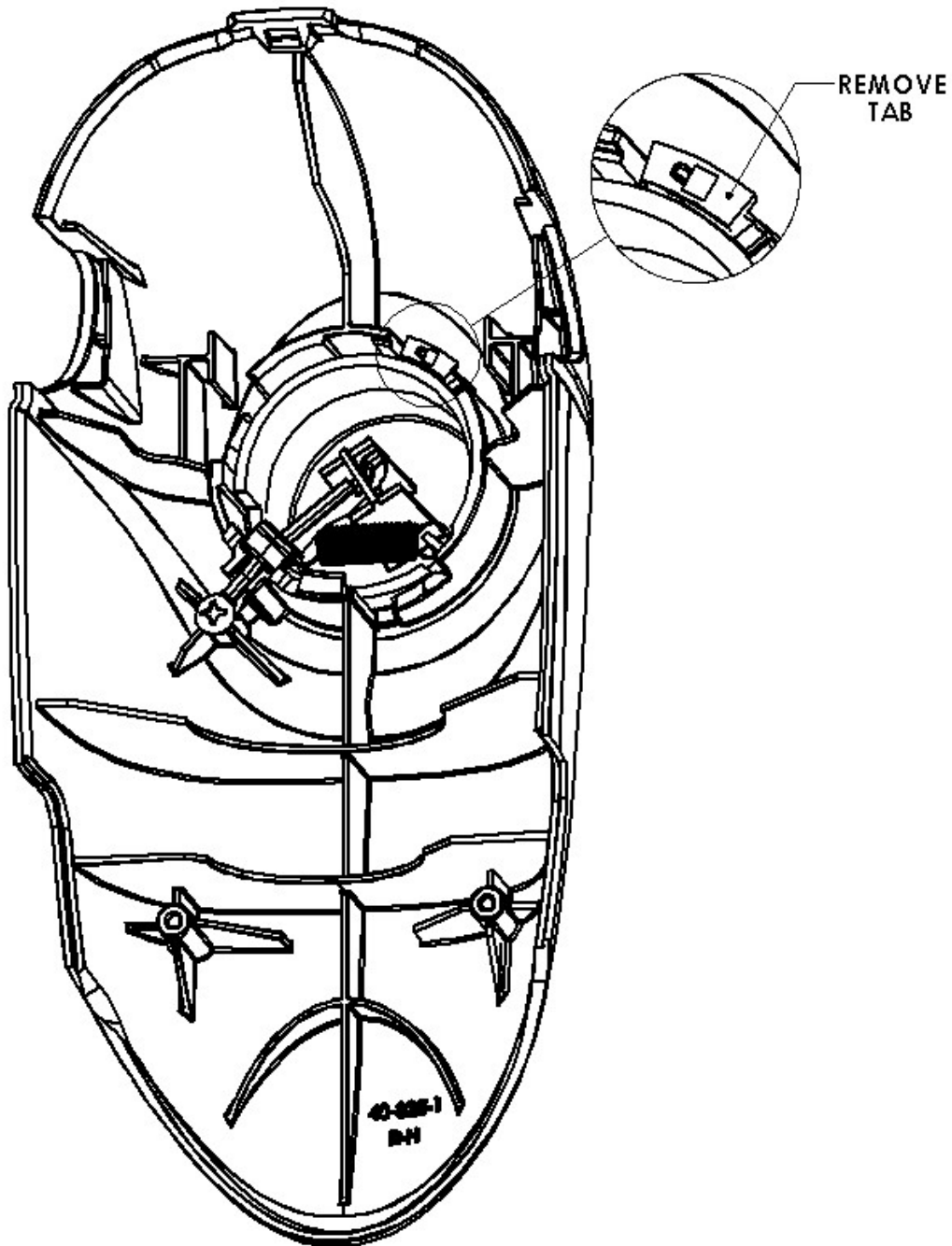

Metering Tip Kits

Table 1: Fusion Metering Tips 100.15K (Provided)

Metering Tip Color	1 GPM Air Gap Proportioner			4 GPM Air Gap Proportioner		
	Oz./gal	ml/L	Ratio : 1	Oz./gal	ml/L	Ratio : 1
Tan	1.37	10.57	93.65	0.37	2.91	343.19
Orange	1.67	12.91	76.48	0.44	3.45	289.14
Turquoise	1.74	13.44	73.43	0.49	3.83	260.27
Pink	3.45	26.28	37.06	0.92	7.12	139.38
Light Blue	4.47	33.73	28.65	1.10	8.49	116.74
Brown	5.04	37.87	25.41	1.40	10.80	91.62
Red	6.89	51.08	18.58	1.78	13.70	72.01
White	7.43	54.87	17.23	1.90	14.60	67.48
Green	7.46	55.06	17.16	1.98	15.26	64.53
Blue	9.14	66.63	14.01	2.54	19.44	50.45
Yellow	14.07	99.07	9.09	4.29	32.46	29.81
Black	17.36	119.45	7.37	4.53	34.19	28.25
Purple	31.36	196.81	4.08	7.67	56.53	16.69
Gray	34.95	214.51	3.66	8.77	64.15	14.59
No Tip	35.95	219.31	3.56	10.54	76.05	12.15

INDUCTION RATES BASED ON WATER THIN PRODUCTS (1 cps)

INDUCTION RATES VARY PRODUCT TO PRODUCT. FIELD TESTS ARE RECOMMENDED.

Table 2: Ultra Lean Metering Tips 100.15KU (Not Provided)

Metering Tip Color	1 GPM Air Gap Proportioner			4 GPM Air Gap Proportioner		
	Oz./gal	ml/L	Ratio : 1	Oz./gal	ml/L	Ratio : 1
Copper	0.47	3.70	269.58	0.14	1.10	904.85
Pumpkin	0.75	5.80	171.35	0.22	1.71	585.42
Burgundy	0.87	6.75	147.10	0.25	1.98	503.37
Lime Green	1.07	8.26	120.14	0.31	2.44	408.69

Metering Tip Kits Continued...

Table 3: Fusion Metering Tips 100.15K (Provided)

Metering Tip Color	1 GPM Action Gap Proportioner			4 GPM Action Gap Proportioner		
	Oz./gal	ml/L	Ratio : 1	Oz./gal	ml/L	Ratio : 1
Tan	0.96	7.46	133.12	0.32	2.49	399.99
Orange	1.20	9.30	106.51	0.38	2.97	335.84
Turquoise	1.43	11.01	89.81	0.45	3.50	285.06
Pink	2.26	17.36	56.62	0.79	6.15	161.72
Light Blue	2.87	21.95	44.56	1.01	7.81	127.09
Brown	3.40	25.86	37.68	1.20	9.30	106.48
Red	4.10	31.08	31.18	1.42	10.99	89.99
White	4.67	35.18	27.43	1.67	12.86	76.79
Green	4.85	36.54	26.38	1.79	13.81	71.40
Blue	6.96	51.58	18.39	2.46	18.83	52.10
Yellow	10.27	74.31	12.46	3.79	28.79	33.74
Black	12.90	91.59	9.92	4.86	36.59	26.34
Purple	26.69	172.54	4.80	11.31	81.19	11.32
Gray	30.36	191.72	4.22	13.76	97.10	9.30
No Tip	45.48	262.17	2.81	24.77	162.15	5.17

INDUCTION RATES BASED ON WATER THIN PRODUCTS (1 cps)
INDUCTION RATES VARY PRODUCT TO PRODUCT. FIELD TESTS ARE RECOMMENDED.

Table 4: Ultra Lean Metering Tips 100.15KU (Not Provided)

Metering Tip Color	1 GPM Action Gap Proportioner			4 GPM Action Gap Proportioner		
	Oz./gal	ml/L	Ratio : 1	Oz./gal	ml/L	Ratio : 1
Copper	0.34	2.67	373.60	0.12	0.94	1060.18
Pumpkin	0.56	4.33	230.23	0.19	1.50	665.14
Burgundy	0.77	6.00	165.66	0.24	1.85	539.29
Lime Green	0.84	6.52	152.39	0.28	2.21	451.24

Replacement Parts: Fusion Unit

Fusion One units can be connected using the Fusion Valve Connector (41.186.1). It would replace the Plug Adapter (40.926.1) on one of the units, and the Inlet Adapter Assembly (40.925.1 & 40.925.2) of the other nit. Please use the orange retainers clips (40.854.1), to secure the connector in place.

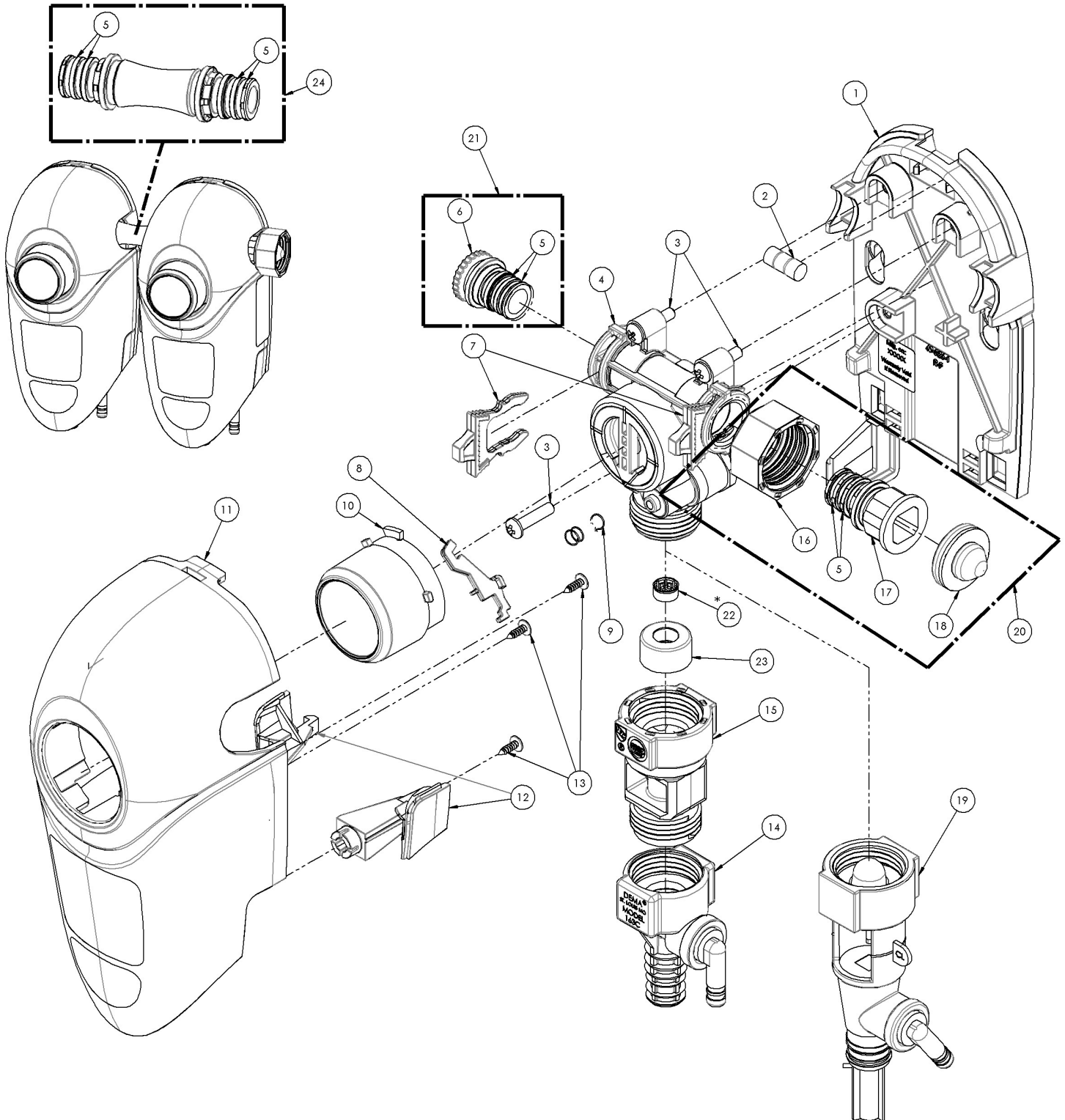

Replacement Part: Fusion Unit Continued...

FUSION REPLACEMENT PARTS			
Item No.	DEMA Part No.	QTY	DESCRIPTION
1	40.826.1	1	BASE, FUSION HK
2	40.970.1	1	FUSION BUBBLE LEVEL
3	44.116.3	3	#8 HI-LO SCREW X 1" LONG
4	40.847.2	1	FUSION VALVE ASSEMBLY (SEE PG. #7 FOR PARTS)
5	63.78	4	O-RING-SEAL EPT (7/16" I.D. X 3/8" O.D. X 1/16" NOM.)
6	40.853.1	1	END PLUG PILOT ACTIVATED VALVE
7	40.854.1	2	RETAINING CLIP PILOT ACTIVATED VALVE
8	40.931.1	1	BOTTOM LEVER, FUSION HK
9	40292.1	1	EXTENSION SPRING
10	40.929.1	1	BUTTON, FUSION HK
11	41.185.1	1	FRONT COVER, FUSION, W/LABELS
12	40.930.1	1	RETENTION LATCH
13	81.20.2	2	#4 X 3/8" HI LO SCREW
14	61.22.3	1	ACTION GAP PROPORTIONER ASSEMBLY (4GPM)
15	16.30	1	ACTION GAP
16	65.10.2	1	STANDARD COUPLING, GARDEN HOSE THREAD
16	98.55.1	1	EURO COUPLING, BRITISH HOSE THREAD
17	40.852.1	1	WATER INLET FITTING, PILOT ACTIVATED VALVE
18	100.38	1	STRAINER WASHER
19	61.22.3BAG	1	AIR GAP PROPORTIONER ASSEMBLY (4GPM)
20	40.925.1	1	FUSION VALVE INLET ADAPTER W/GHT, ASSEMBLY
20	40.925.2	1	FUSION VALVE INLET ADAPTER W/BRITISH PSPP, ASSEMBLY
20	40.925.3	1	FUSION VALVE INLET ADAPTER W/GHT, ASSEMBLY, PLASTIC
20	40.925.4	1	FUSION VALVE INLET ADAPTER W/BSPP, ASSEMBLY, PLASTIC
21	40.926.1	1	FUSION VALVE PLUG ADAPTER, ASSEMBLY
22	77.2.1.06	1	FLOW DISC, PINK, [1.06(GPM) / 4(L/MIN)] <i>*Not Installed W/Air Gap Models*</i>
22	77.6.2.64	1	FLOW DISC, YELLOW, [2.64(GPM) / 10(L/MIN)]
22	40.570.1	1	FLOW DISC, NATURAL, [4.45(GPM) / 16.85(L/MIN)]
23	89.18.1	1	RETAINER, FLOW DISC
24	41.186.1	-	FUSION VALVE CONNECTOR
25	89.30.GAP	1	HOSE HANGER ASSY. FOR GAP MODELS ONLY

Replacement Parts Valve Body

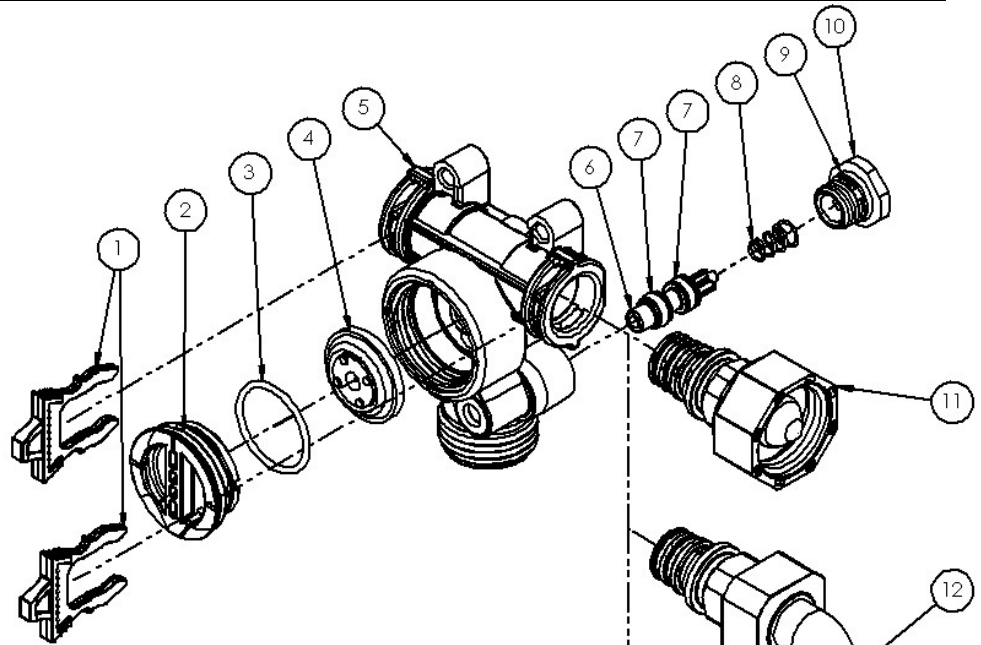

VALVE REPLACEMENT PARTS

Item No.	DEMA Part No.	QTY	DESCRIPTION
1	40.854.1	2	RETAINING CLIP PILOT ACTIVATED VALVE
2	41.058.1	1	DIAPHRAGM CAP
3	619.21	1	O-RING SEAL EPDM (15/16" X 1/16")
4	98.26.1	1	1-1/16" DIAPHRAGM
5	40.824.1	1	VALVE BODY
6	40.849.1	1	BUTTON, PILOT ACTIVATED VALVE
7	640.106	2	O-RING SEAL (3/16"ID X 3/8"OD X 3/32"NOM.)
8	98.39.2	1	RETURN SPRING
9	63.78	1	O-RING-SEAL EPT (7/16" I.D. X 9/16" O.D. X 1/16 NOM.)
10	40.851.1	1	BOTTOM CAP
11	40.925.1	1	FUSION INLET ADAPTER W/GHT
11	40.925.2	1	FUSION INLET ADAPTER W/BSPP
11	40.925.3	1	FUSION INLET ADAPTER W/GHT, PLASTIC
11	40.925.4	1	FUSION INLET ADAPTER W/BSPP, PLASTIC
12	40.927.1	1	3/8" ELBOW COMPRESSION INLET FITTING
13	40.927.2	1	3/8" STRAIGHT COMPRESSION INLET FITTING
14	40.927.3	1	3/8" JOHN GUEST PUSH-ON INLET FITTING
15	40.927.4	1	3/8" ELBOW JOHN GUEST PUSH-ON INLET FITTING
16	40.927.5	1	3/8" BARB INLET FITTING

Trouble Shooting

Symptom	Probable Cause	Remedy
Water Valve Does Not Shut Off After Use	Water pressure is above recommended range	Recommended water pressure is 30-70psi (2-5bar), install #66.43 pressure regulator
	Hole in the diaphragm	Replace the diaphragm
	Debris on the diaphragm or the valve actuation button	Rinse the diaphragm or button assembly
Proportioner Continues To Draw Chemical After Water Valve Is Shut Off	Concentrated chemical is positioned higher than the proportioner and is siphoning chemical	Move chemical container so it is lower than the proportioner
Activation Button Does Not Return To Off Position	Spring is missing from button	Replace spring, #64.50.1
Proportioner Does Not Draw Chemical Properly	Insufficient water pressure	Minimum allowable water pressure is 20psi (1.38bar)
	Foot valve/SafeLink cap is clogged	Soak in hot water to clean
	Metering tip is clogged	Soak in hot water to clean
	Mineral deposits are located on air gap nozzle	Soak nozzle and inlet screen in hot water or in a mineral deposit removal chemical
	Proportioner elbow is loose, or O-ring seal has failed, allowing air in	Tighten seal, inspect O-ring condition, replace if needed, #63.78
Air Gap Is Spraying Or Dripping	Mineral deposits are located on air gap nozzle	Soak nozzle and inlet screen in hot water or in a mineral deposit removal chemical
Leaking At Action Gap	Bucket fill tube is raised higher than proportioner	Do not raise bucket fill tube higher than proportioner, ensure dispenser is mounted a minimum of 4' (1.2m) off floor
Leaking At Water Valve Fittings	Retainer clip (orange) is not present	Replace retainer clip, #40.854.1
Leaking At Threaded Connections	Connection between dispenser and water supply is too loose or strainer washer is missing	Inspect connection, verify strainer washer is present, tighten fittings
Leaking At Threaded Connections	Connection between dispenser and water supply is too loose or strainer washer is missing	Inspect connections, tighten fittings
	Proportioner and/or backflow preventer is too loose	Inspect connections, tighten fittings

Product Dimensions

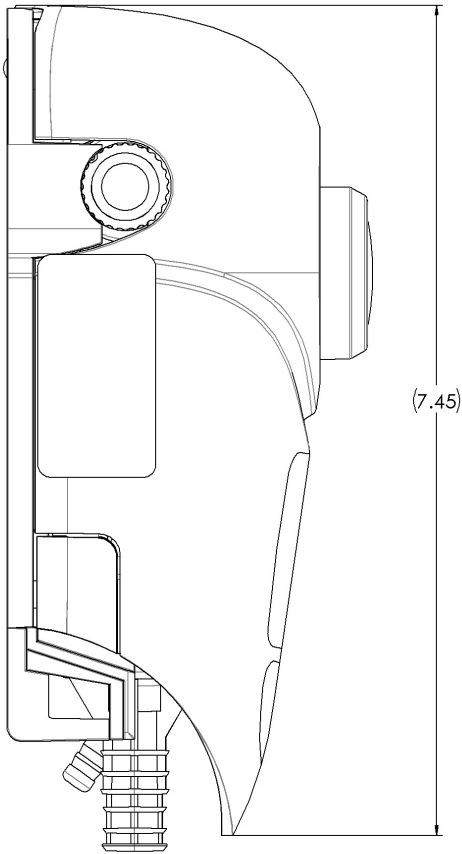

**FUSION ONE
LEFT END VIEW**

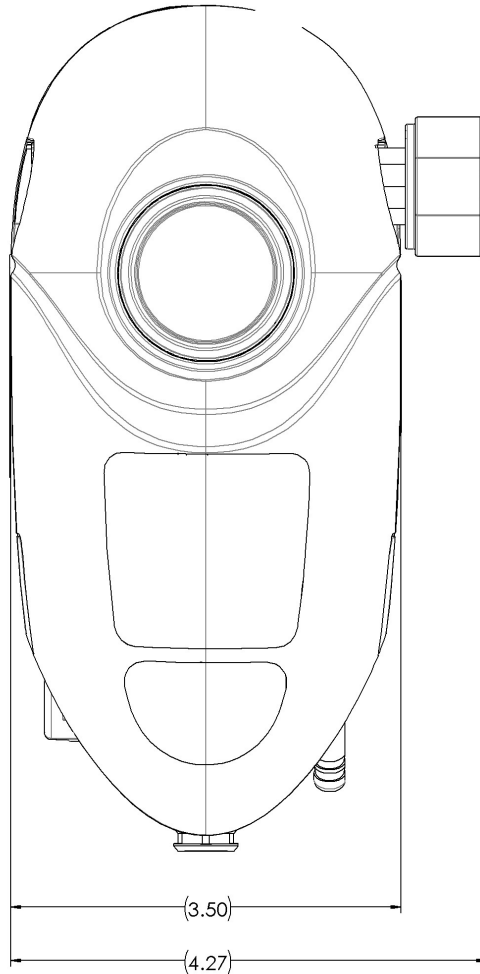

**FUSION ONE
FRONT VIEW**

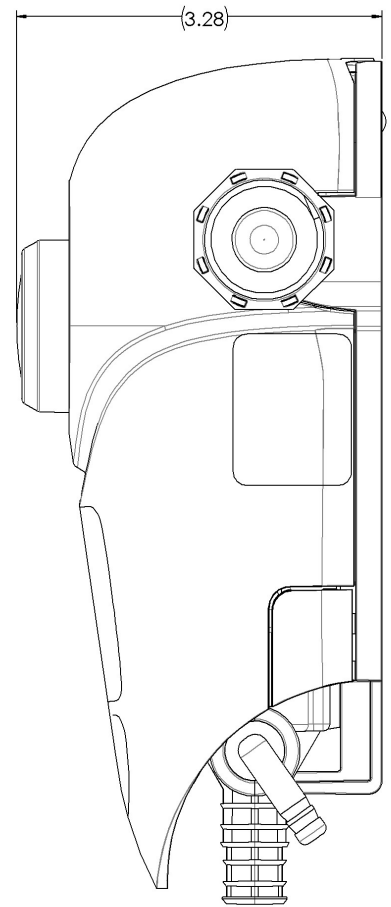

**FUSION ONE
RIGHT END VIEW**

Specifications

- Operation Pressure Rating: 20psi – 95psi
- Safety Pressure Rating: 125psi
- Water Temperature Rating: 45°F (7°C) – 125°F (50°C) Max
- Back Flow Protection – ASSE 1055 (Action Gap & Air Gap)
- ASME A112.1.2 (Air Gap)

Warranty

Merchandise Returns

No Merchandise Will Be Returned For Credit Without DEMA'S Written Permission. Returned Merchandise Authorization Number Is Required In Advance Of Return.

Product Warranty

DEMA products are warranted against defective material and workmanship under normal use and service for one year from the date of manufacture. This limited warranty does not apply to any products that have a normal life shorter than one year or failure and damage caused by chemicals, corrosion, physical abuse, or misapplication. Rubber and synthetic rubber parts such as “o”-rings, diaphragms, PVC tubing, and gaskets are considered expendable and are not covered under warranty. This warranty is extended only to the original buyer of DEMA products. If products are altered or repaired without prior approval DEMA, this warranty is void.

Defective units or parts should be returned to the factory with transportation prepaid. If inspection shows them to be defective, they will be repaired or replaced without charge, F.O.B. factory. DEMA assumes no liability for damages. Return merchandise authorization number must be granted in advance of return units for repair or replacement (See “Merchandise Returns” above).

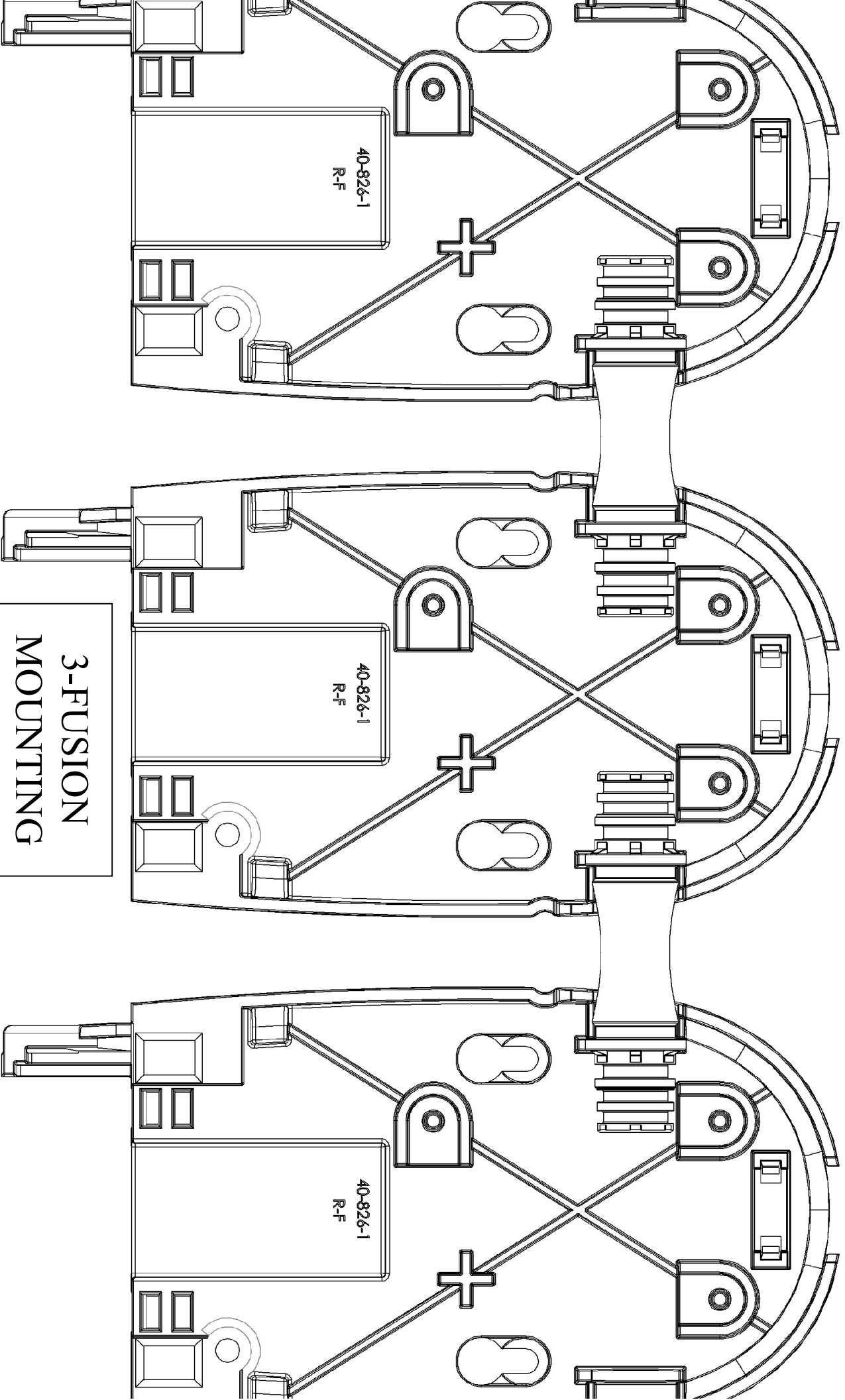

3-FUSION
MOUNTING
TEMPLATE