

THE INFORMATION CONTAINED  
IN THIS DRAWING IS THE SOLE  
PROPERTY OF PUVAC HUNGARY KFT.  
REPRODUCTION IN PART OR WHOLE  
WITHOUT THE WRITTEN PERMISSION  
OF PUVAC HUNGARY KFT. PROHIBITED.

ART.NR. 7001305 -	REV. 01	PROJECTION 	MATERIAL	
TITLE ELECTRO SET - ASSY CPL S3 120V US			FINISH -	
NOTES: -			DESIGNER PALLAG DESIGN	PROJECT P2125 - Puvac - Vacuum Cleaner
			DATE	UNLESS OTHERWISE SPECIFIED: DIMENSIONS ARE IN MILLIMETERS.
			LAST CHANGE	FOR UNDEFINED MACHINING TOLERANCES USE ISO 2768-MK.
			DATE 28-Aug-2023	FOR WELDING SS-EN ISO 13920-BF, MACHINED SURFACE FINISH ACCORDING TO ISO 1302. FOR UNDEFINED GEOMETRY SEE 3D MODEL.
			STATUS	
NO.	CHANGE	DATE	DESIGNER	SIZE: A3
			SHEET 1 / 1	

S303 US cables (A7001305)							
		Color	Dia	Plug 1	Cable length(cm)	Plug 2	
Cover assy 7001237	101	White	1,5mm2	7500182	25	900757	Plug(7500185) 4 - Hour Meter 1
	102	White	1,5mm2	7500182	25	900757	Plug(7500185) 2 - Switcho top left
	103	White	1,5mm2	7500182	25	900757	Plug(7500185) 1 - Switch bottom left
	104	Black	1,5mm2	7500182	25	900757	Plug(7500185) 3 - Switch bottom right
	105	Black	1,5mm2	7500182	25	900757	Plug(7500185) 5 - Switch top right
	106	Black	1,5mm2	7500182	25	109009	Plug(7500185) 6 - Buzzer x1
	107	Black	1,5mm2	900275	15	900275	Switch top right - Hour meter 2
	108	Black	1,5mm2	900757	15	109009	Hour meter 2 - Buzzer x2
	109	White	1,5mm2	900275	15	900275	Switch top left - Hour meter x1
Motor assy 7001235	110	Black	1,5mm2	7500184	25	900757	Plug (7500183) 6 - Vacuum switch
	111	White	1,5mm2	7500184	25	900757	Plug (7500183) 4 - Vacuum switch
	112	MEB + White	1,5mm2	MEB 110V Blue(Ue)	(20)+50	7500184	MEB 110V Blue(Ue) - 900761 - Plug (7500183) 2
	113	MEB Black	1,5mm2	109009	20	MEB 110V Black(Ua)	7500193(Red) - MEB 110V Black(Ua)
	114	MEB + Black	1,5mm2	MEB 110V Brown(Ue)	(20)+50	7500184	MEB 110V Brown(Ue) - 900761 - Plug (7500183) 5
	115	MEB Blue	1,5mm2	109009	20	MEB 110V Blue(Ua)	7500193(Blue) - MEB 110V Blue(Ua)
	116	Black	1,5mm2	900765	43	109009	Motor 1/1 - 7500194(red)
	117	Black	1,5mm2	900765	32	109009	Motor 2/1 - 7500194(red)
	118	Black	1,5mm2	900765	28	109009	Motor 3/1 - 7500194(red)
	119	White	1,5mm2	900765	43	109009	Motor 3/2 - 7500194(blue)
	120	White	1,5mm2	900765	32	109009	Motor 2/2 - 7500194(blue)
	121	White	1,5mm2	900765	28	109009	Motor 1/2 - 7500194(blue)
	122	Yellow/Green	1,5mm3	900757	25	900478	Motor 1/Pe- GND
	123	Yellow/Green	1,5mm4	900757	25	900478	Motor 2/Pe- GND
124	Yellow/Green	1,5mm5	900757	35	900478	Motor 3/Pe- GND	
Power cord 7001215		black			30	7500184	Plug (7500183) 3
		white			30	7500184	Plug (7500183) 1
		green			30	109007	GND

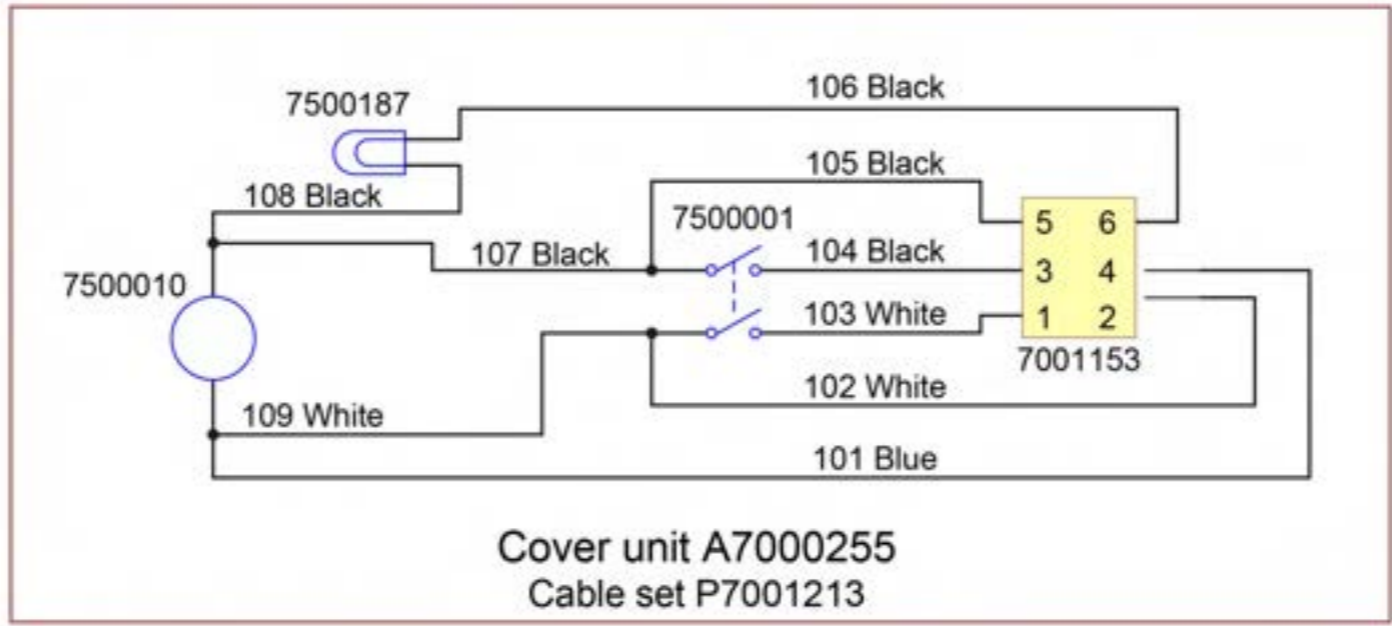
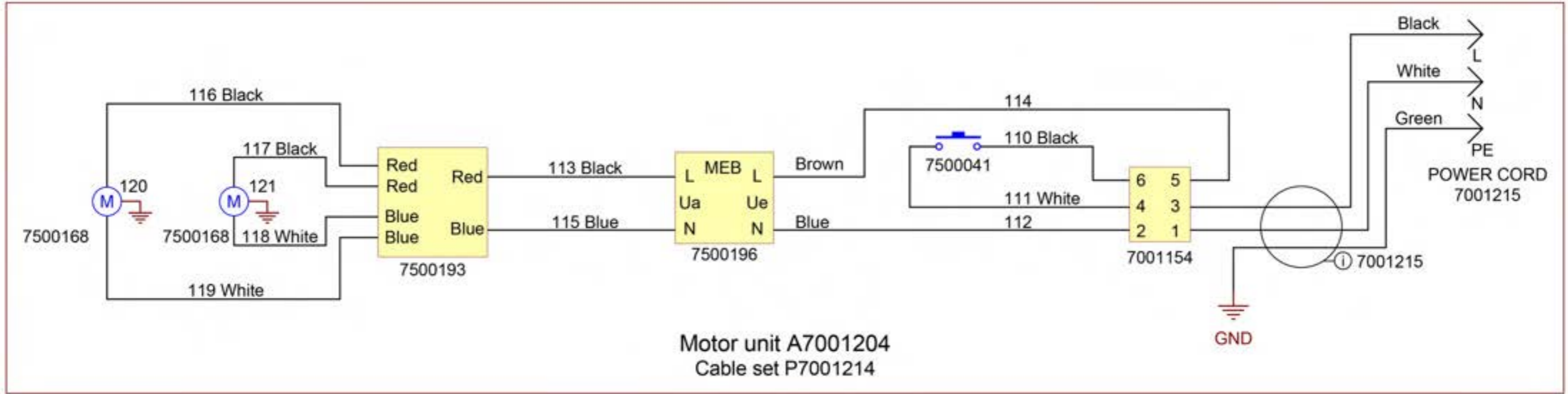

THE INFORMATION CONTAINED  
IN THIS DRAWING IS THE SOLE  
PROPERTY OF PUVAC HUNGARY KFT.  
REPRODUCTION IN PART OR WHOLE  
WITHOUT THE WRITTEN PERMISSION  
OF PUVAC HUNGARY KFT. PROHIBITED.

ART.NR. <b>7001302 -</b>	REV. <b>01</b>	PROJECTION 	MATERIAL	
TITLE <b>ELECTRO SET - ASSY CPL S2 120V US</b>			FINISH -	
NOTES: -			DESIGNER PALLAG DESIGN	PROJECT P2125 - Puvac - Vacuum Cleaner
			DATE	UNLESS OTHERWISE SPECIFIED: DIMENSIONS ARE IN MILLIMETERS.
			LAST CHANGE	FOR UNDEFINED MACHINING TOLERANCES USE ISO 2768-MK.
			DATE 28-Aug-2023	FOR WELDING SS-EN ISO 13920-BF, MACHINED SURFACE FINISH
			STATUS	ACCORDING TO ISO 1302. FOR UNDEFINED GEOMETRY SEE 3D MODEL.
NO.	CHANGE	DATE	DESIGNER	SIZE: A3
			SHEET 1 / 1	

S203 US cables (A7001302)							
		Color	Dia	Plug 1	Cable length(cm)	Plug 2	
Cover assy 7001213	101	Blue	1,5mm2	7500182	25	900757	Plug(7500185) 4 - Hour Meter 1
	102	White	1,5mm2	7500182	25	900757	Plug(7500185) 2 - Switch top left
	103	White	1,5mm2	7500182	25	900757	Plug(7500185) 1 - Switch bottom left
	104	Black	1,5mm2	7500182	25	900757	Plug(7500185) 3 - Switch bottom right
	105	Black	1,5mm2	7500182	25	900757	Plug(7500185) 5 - Switch top right
	106	Black	1,5mm2	7500182	25	109009	Plug(7500185) 6 - Buzzer x1
	107	Black	1,5mm2	900275	15	900275	Switch top right - Hour meter 2
	108	Black	1,5mm2	900757	15	109009	Hour meter 2 - Buzzer x2
	109	White	1,5mm2	900275	15	900275	Switch top left - Hour meter x1
Motor assy 7001214	110	Black	1,5mm2	7500184	25	900757	Plug (7500183) 6 - Vacuum switch
	111	White	1,5mm2	7500184	25	900757	Plug (7500183) 4 - Vacuum switch
	112	MEB Blue + White	1,5mm2	7500184	(20)+50	MEB 110V Blue(Ue)	Plug (7500183) 2 - 900761 - MEB 110V Blue(Ue)
	113	MEB Black	1,5mm2	109009	20	MEB 110V Black(Ua)	7500193(Red) - MEB 110V Black(Ua)
	114	MEB Brown + Black	1,5mm2	7500184	(20)+50	MEB 110V Brown(Ue)	Plug (7500183) 5 - 900761 - MEB 110V Brown(Ue)
	115	MEB Blue	1,5mm2	109009	20	MEB 110V Blue(Ua)	7500193(Blue) - MEB 110V Blue(Ua)
	116	Black	1,5mm2	900765	25	109009	Motor 1/1 - 7500193(red)
	117	Black	1,5mm2	900765	25	109009	Motor 2/1 - 7500193(red)
	118	White	1,5mm2	900765	25	109009	Motor 1/2 - 7500193(blue)
	119	White	1,5mm2	900765	25	109009	Motor 2/2 - 7500193(blue)
	120	Yellow/Green	1,5mm3	900757	25	900478	Motor 1/Pe - GND
121	Yellow/Green	1,5mm4	900757	25	900478	Motor 2/Pe - GND	
Power cord 7001215		black			30	7500184	Plug (7500183) 3
		white			30	7500184	Plug (7500183) 1
		green			30	109007	GND