



SPARE PARTS LIST

SURFACE PREPARATION EQUIPMENT

PG 820, To machine 0904-1 and forward,
2009-07

B1 PG820

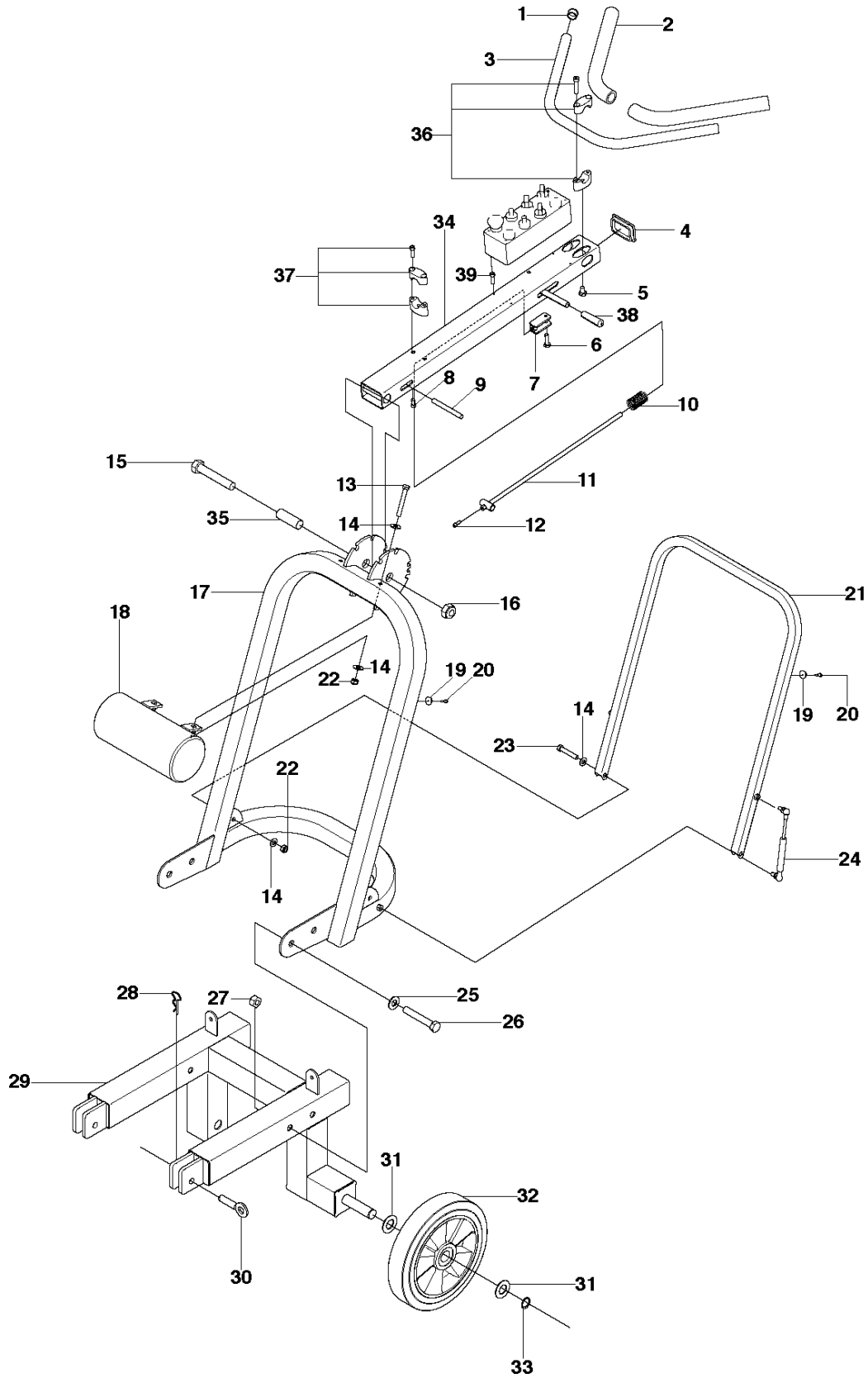

Ref	Part No	Description	Remark	QTY KIT
1	543 04 60-41	EMBOUT REF 320 GL 25/		2
2	502 54 49-22	RUBBER COVER		2
3	502 54 49-20	HANDLE TUBE		1
4	516 05 90-01	HUB CAP		1
5	725 24 89-76	SCREW EHHM		2
6	725 24 55-76	SCREW EHHM		1
7	502 54 49-05	BRACKET		1
8	725 54 45-01	SCREW IHSCM		2
9	516 05 93-01	PIN		1
10	502 54 49-27	COMPRESSION SPRING		1
11	516 05 95-01	ROD		1
12	724 13 64-51	SCREW CRPANM		1
13	725 25 07-51	SCREW EHHM		2
14	734 11 72-01	WASHER		8
15	504 75 07-01	SCREW		1
16	504 75 06-01	LOCK NUT		1
17	502 54 47-01	CHASSIS		1
18	504 73 04-01	WEIGHT		1
19	516 05 96-01	BUMPER		4
20	521 88 65-01	SCREW		4
21	502 54 47-07	BAR		1
22	732 25 20-01	HEXAGON LOCKING NUT		4
23	725 25 02-51	SCREW EHHM		2
24	502 54 47-11	GAS STRUT		2
25	734 11 86-01	WASHER		4
26	504 75 13-01	SCREW EHHM		4
27	731 23 24-01	HEXAGON NUT		2
28	721 68 02-51	SPRING COTTER		2
29	502 54 48-01	CHASSIS		1
30	504 72 97-01	PIN		2
31	504 75 14-01	WASHER		4
32	502 54 50-01	WHEEL		2
33	735 31 26-00	CIRCLIP		2
34	502 54 49-02	HANDLEBAR ASSY		1
35	516 05 97-01	SLEEVE		1
36	502 54 49-25	HANDLE BAR		2
37	502 54 49-26	HANDLE BAR		1
38	502 54 49-23	RUBBER COVER		1
39	504 75 20-01	SCREW CRCSFT		4

B2 PG820

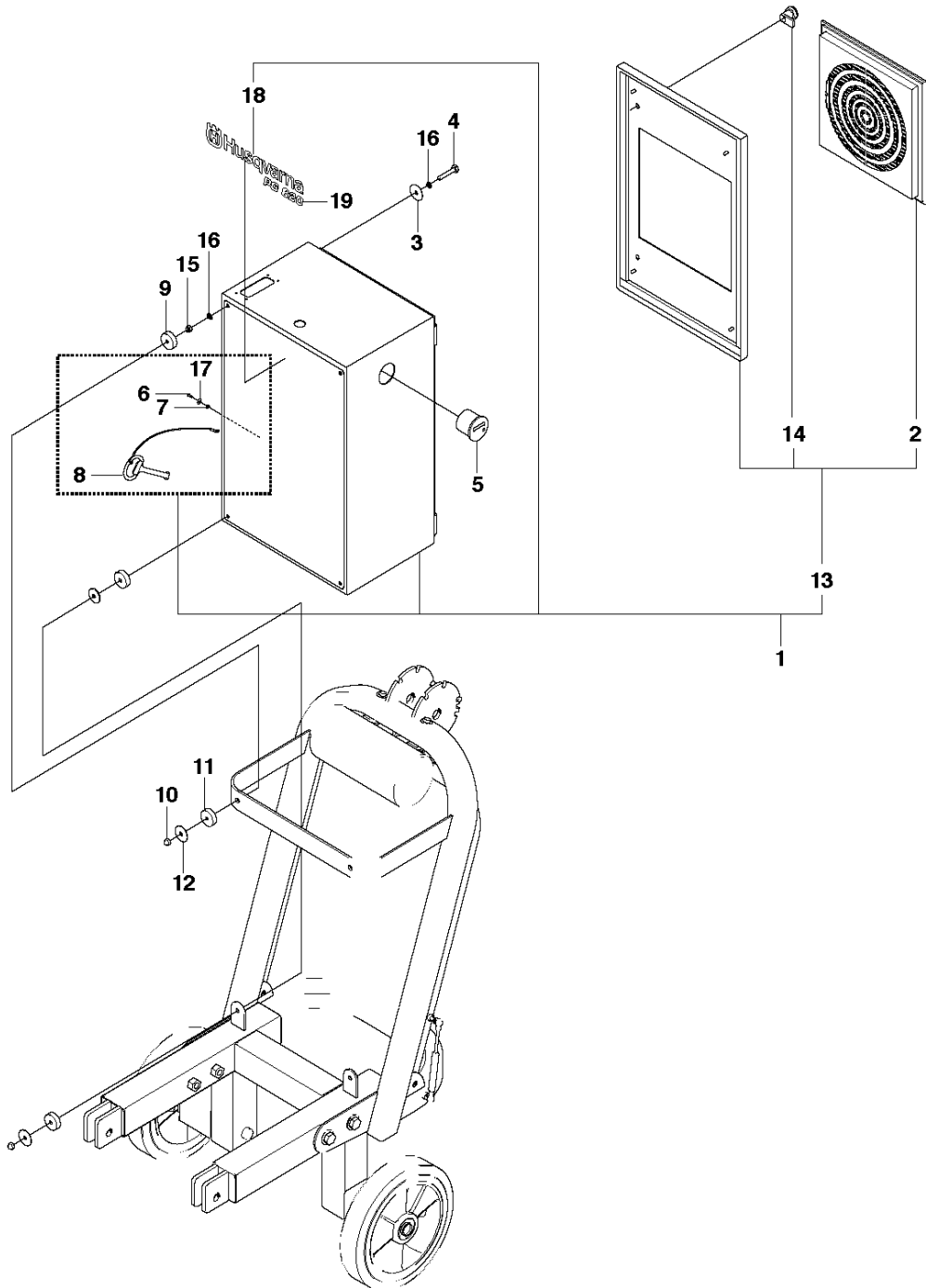

Ref	Part No	Description	Remark	QTY	KIT
1	574 44 08-01	ELECTRIC BOX		1	1, 13
1	577 20 61-01	ELECTRIC BOX	JP	1	1, 13
1	574 44 08-02	ELECTRIC BOX	UL	1	
2	502 54 41-01	VENT KIT		1	
3	504 74 73-01	WASHER		4	
4	725 24 61-71	SCREW EHHM		4	
5	504 74 13-01	HOUR METER		1	
5	580 88 17-01	HOUR METER	UL	1	
6	541 40 51-78	SCREW IHANM		1	
7	734 11 52-01	WASHER		1	
8	574 44 11-01	KEY		1	
9	502 53 39-01	WASHER		4	
10	543 04 47-66	NUT		4	
11	515 98 41-01	WASHER		4	
12	521 88 67-01	WASHER		4	
13	574 44 10-01	ELECTRIC BOX		1	1
14	516 05 98-01	LATCH		2	1, 13
15	732 25 18-01	HEXAGON LOCKING NUT		4	
16	735 21 64-01	LOCK WASHER		8	
17	735 11 53-01	WASHER		1	
18	525 48 88-01	DECAL		1	
19	525 48 83-01	DECAL		1	

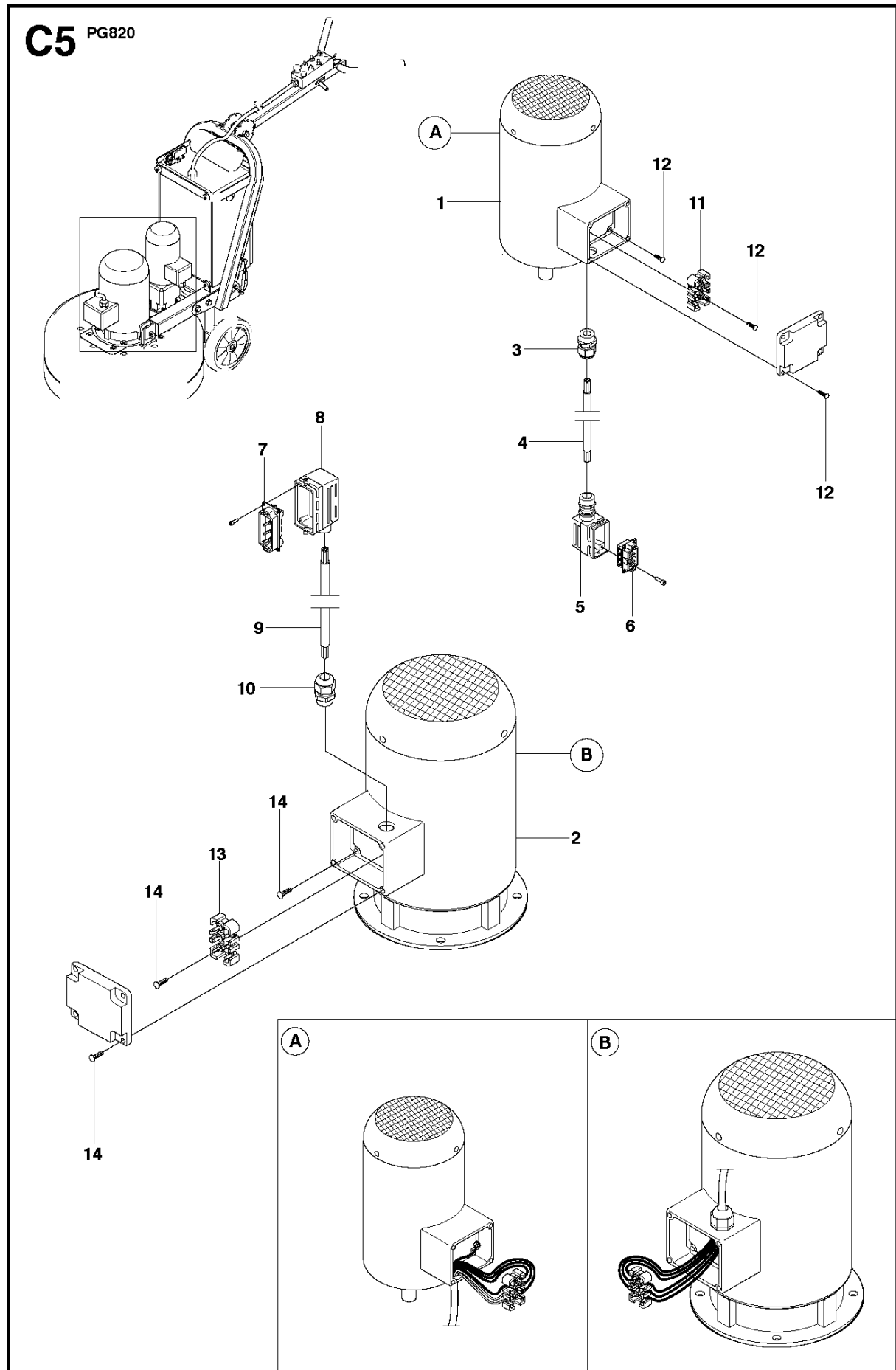

ELECTRICAL

PG 820, To machine 0904-1 and forward, 2009-07

Ref	Part No	Description	Remark	QTY	KIT
1	502 53 57-01	ELECTRIC MOTOR		1	
1	576 93 32-01	MOTOR	JP	1	
2	502 53 52-01	ELECTRIC MOTOR		1	
2	580 68 69-01	ELECTRIC MOTOR	JP	1	
3	516 06 12-01	GROMMET		1	
4	504 74 03-01	POWER CABLE		1	5-6
4	504 74 03-02	POWER CABLE	UL	1	5-6
5	516 06 13-01	HOOD		1	
6	516 06 14-01	CONNECTOR		1	
7	516 06 15-01	CONNECTOR		1	
7	504 76 25-01	CONNECTOR	JP	1	
8	516 06 16-01	HOOD		1	
9	516 06 17-01	CABLE		1	7-8
9	516 06 17-02	CABLE	UL	1	7-8
9	577 20 67-01	CABLE	JP	1	
10	516 06 18-01	GROMMET		1	
10	502 54 39-01	GROMMET	JP	1	
11	516 06 19-01	TERMINAL BLOCK		1	
12	723 13 27-51	SCREW SLCHM		9	
13	516 06 20-01	TERMINAL BLOCK		1	
14	724 13 68-51	SCREW CRPANM		9	

C2 PG820

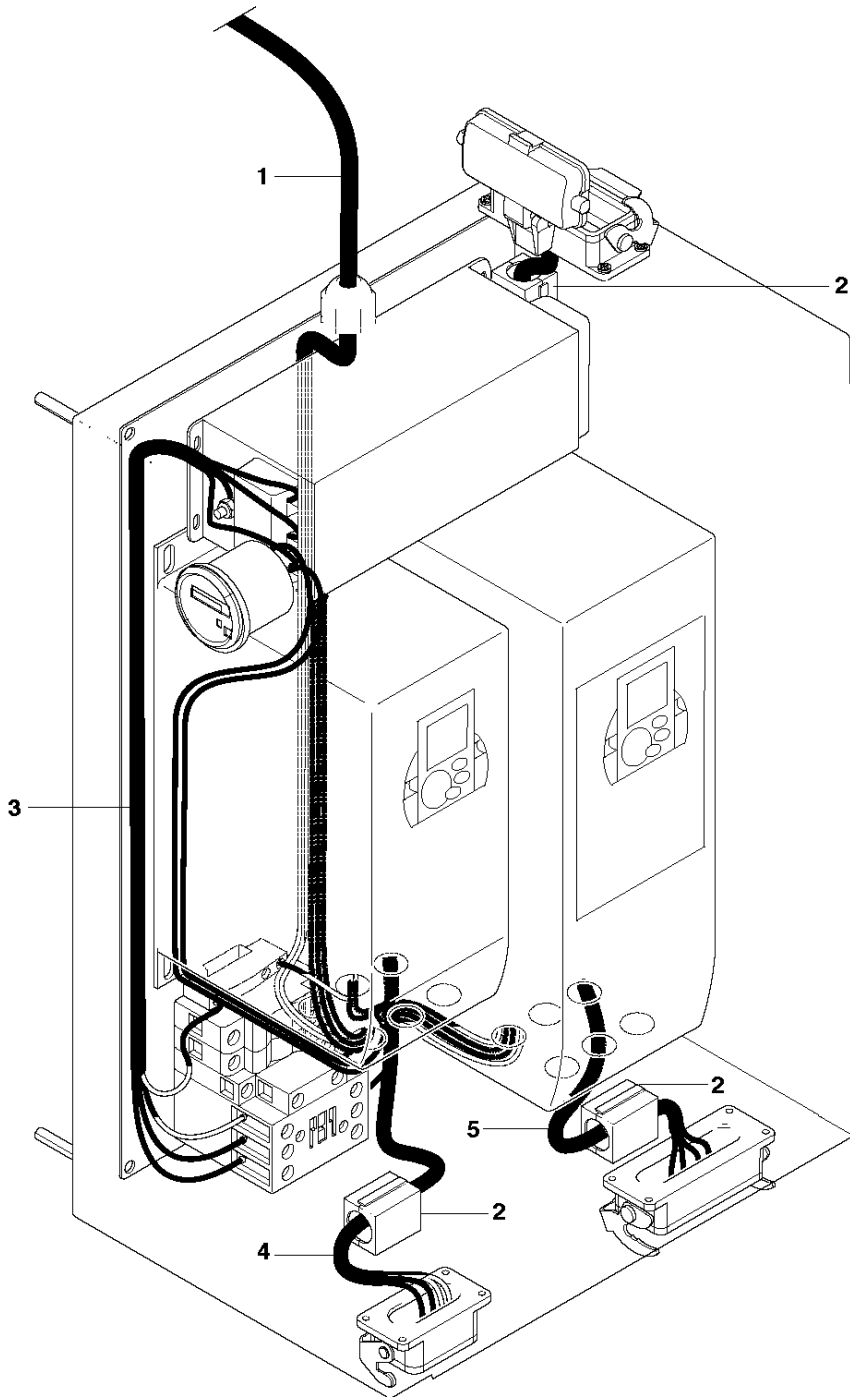

Ref	Part No	Description	Remark	QTY KIT
1	502 54 42-01	WIRING		1
1	577 20 62-01	WIRING	JP	1
1	581 11 09-01	WIRING	UL	1
2	504 71 72-01	FERRITE		3
3	516 05 77-01	CABLE		1
3	516 05 77-02	CABLE	UL	1
3	577206301	CABLE	JP	1
4	516 05 76-01	CABLE		1
4	516 05 76-02	CABLE	UL	1
5	516 05 75-01	CABLE		1
5	516 05 75-02	CABLE	UL	1
5	577206501	CABLE	JP	1

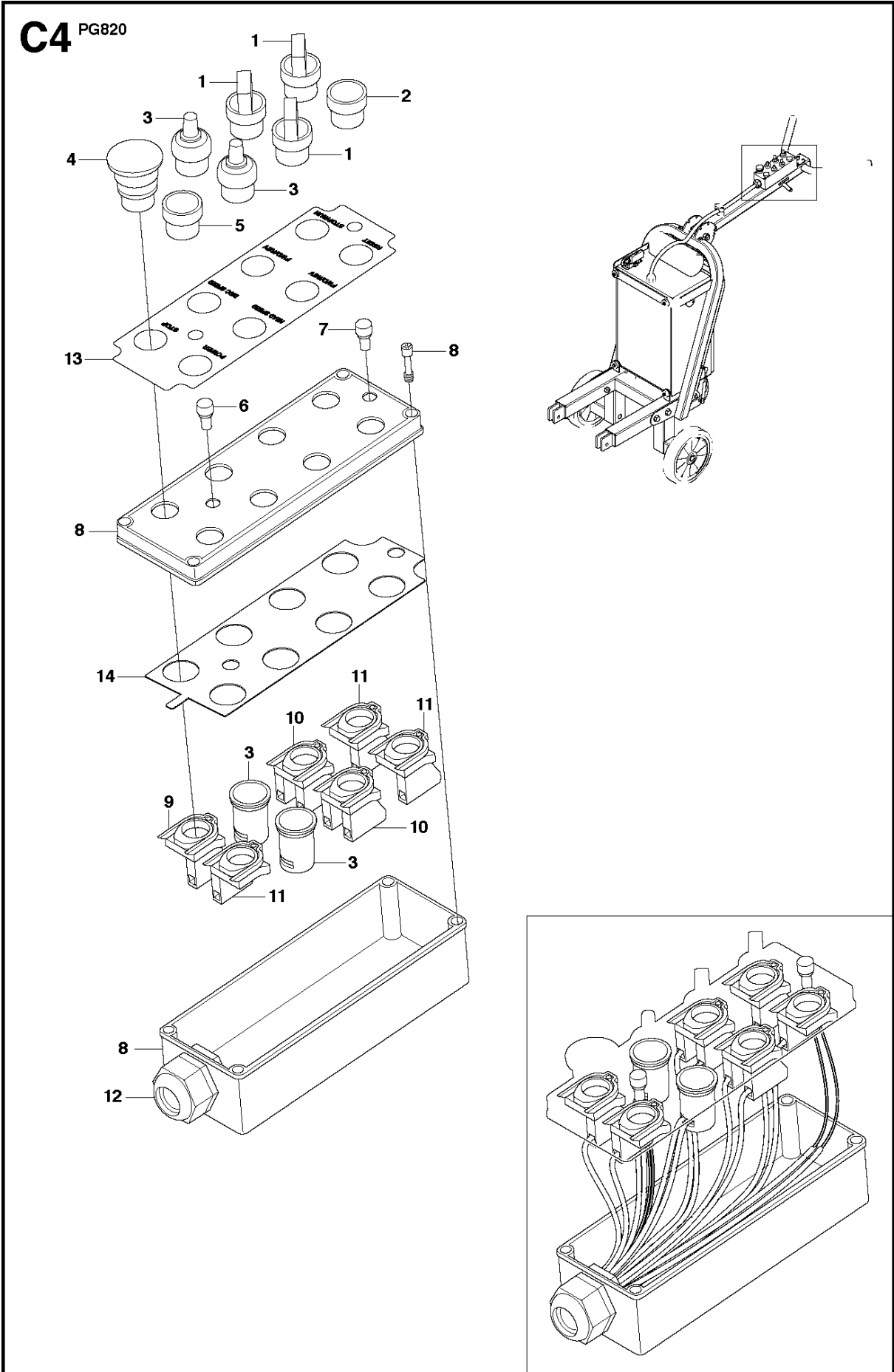

ELECTRICAL

PG 820, To machine 0904-1 and forward, 2009-07

Ref	Part No	Description	Remark	QTY KIT
1	504 73 86-01	SWITCH		3
2	504 73 88-01	PUSH BUTTON		1
3	502 54 29-01	POTENTIOMETER		2
4	504 73 94-01	BUTTON		1
5	504 73 90-01	PUSH BUTTON		1
6	504 73 97-01	LAMP		1
6	580 88 16-02	LAMP	UL	1
7	504 73 96-01	LAMP		1
7	580 88 16-01	LAMP	UL	1
8	502 54 46-01	ELECTRIC BOX		1
9	504 73 95-01	BUTTON BODY		1
10	504 73 87-01	BUTTON BODY		2
11	504 73 89-01	BUTTON BODY		3
12	502 54 39-01	GROMMET		1
13	502 54 33-01	DECAL		1
14	504 75 82-01	PLATE		1

C3 PG820

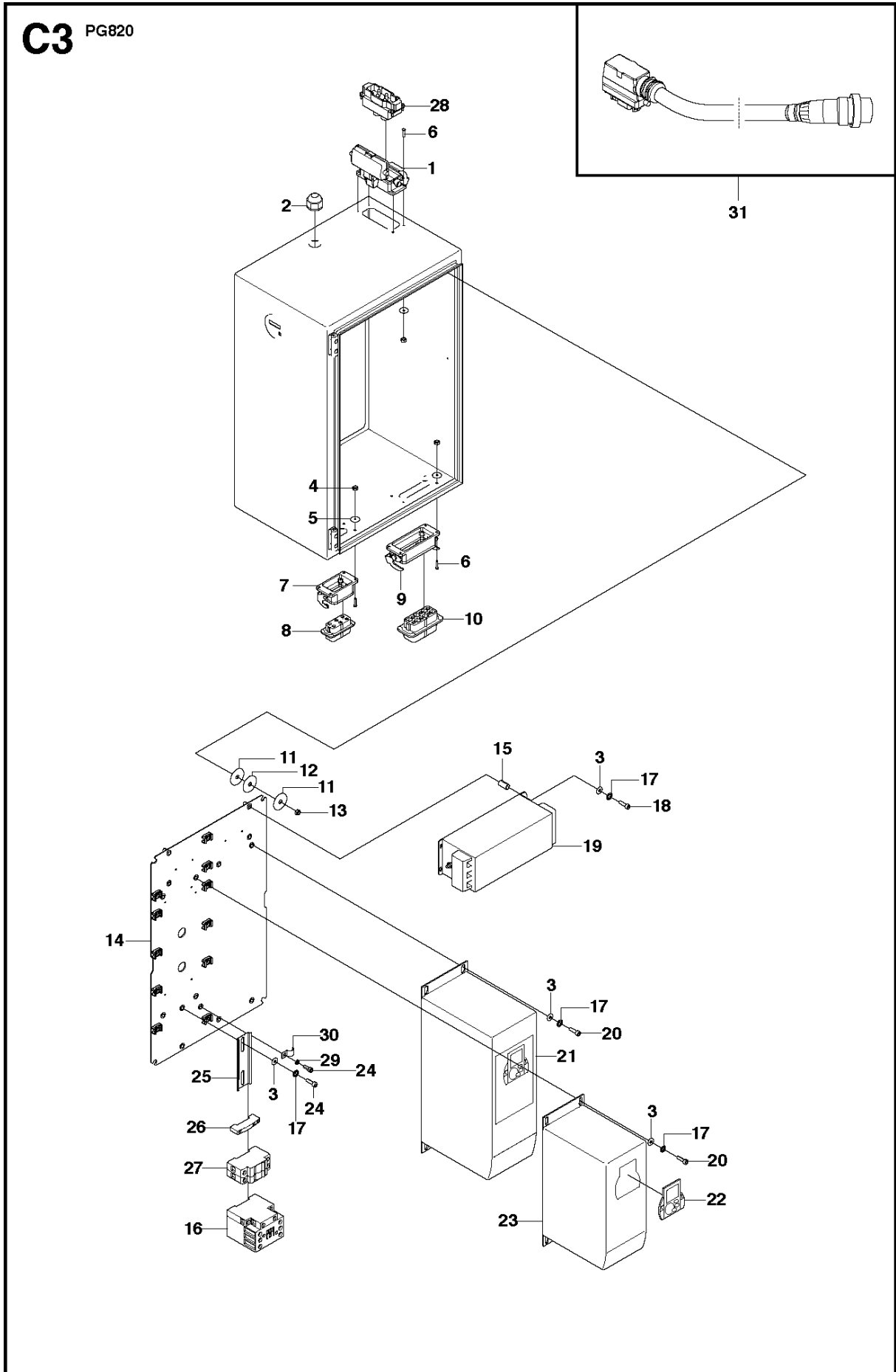

ELECTRICAL

PG 820, To machine 0904-1 and forward, 2009-07

Ref	Part No	Description	Remark	QTY KIT
1	516 06 06-02	HOUSING		1
2	502 54 39-01	GROMMET		2
3	734 11 54-41	WASHER		
4	732 25 12-01	HEXAGON LOCKING NUT		12
5	734 11 36-01	WASHER		12
6	724 12 93-51	SCREW CRPANM		12
7	516 06 04-01	HOUSING		1
8	516 06 05-01	CONNECTOR		1
9	516 06 06-01	HOUSING		1
10	516 06 07-01	CONNECTOR		1
10	504 76 26-01	CONNECTOR	JP	1
11	521 88 67-01	WASHER		8
12	516 06 01-01	WASHER		8
13	732 25 18-01	HEXAGON LOCKING NUT		4
14	574 44 12-01	PLATE		1
14	577 20 66-01	PLATE	JP	1
15	504 75 81-01	SPACER TUBE	Not UL	4
16	502 54 36-01	CONTACTOR		1
16	581031801	TBD	JP	1
17	735 11 53-01	WASHER		
18	725 53 80-01	SCREW IHSCM	NOT UL	4
19	504 71 71-01	FILTER	Not UL	1
20	725 53 70-51	SCREW IHSCM		8
21	502 54 25-02	FREQUENCY INVERTER		1
21	576 93 53-01	FREQUENCY INVERTER	JP	1
22	516 06 10-01	PANEL		2
22	505 46 40-01	KEYBOARD		2
23	502 54 26-01	FREQUENCY INVERTER		1
23	576 93 54-01	FREQUENCY INVERTER	JP	1
24	725 53 68-01	SCREW IHSCM		3
25	516 06 11-01	RAIL		1
26	502 54 38-01	TERMINAL BLOCK		1
27	502 54 37-01	CIRCUIT BREAKER		1
27	578 35 05-01	CIRCUIT BREAKER	UL	1
28	504 76 25-01	CONNECTOR		1
29	735 21 53-01	LOCK WASHER		1
30	504 75 84-01	CABLE CLAMP		1
31	574 44 13-01	PLUG	EU	1
31	574 44 13-02	PLUG	AU	1
31	574 44 13-03	PLUG	UL	1
31	574 44 13-04	PLUG	JP	1

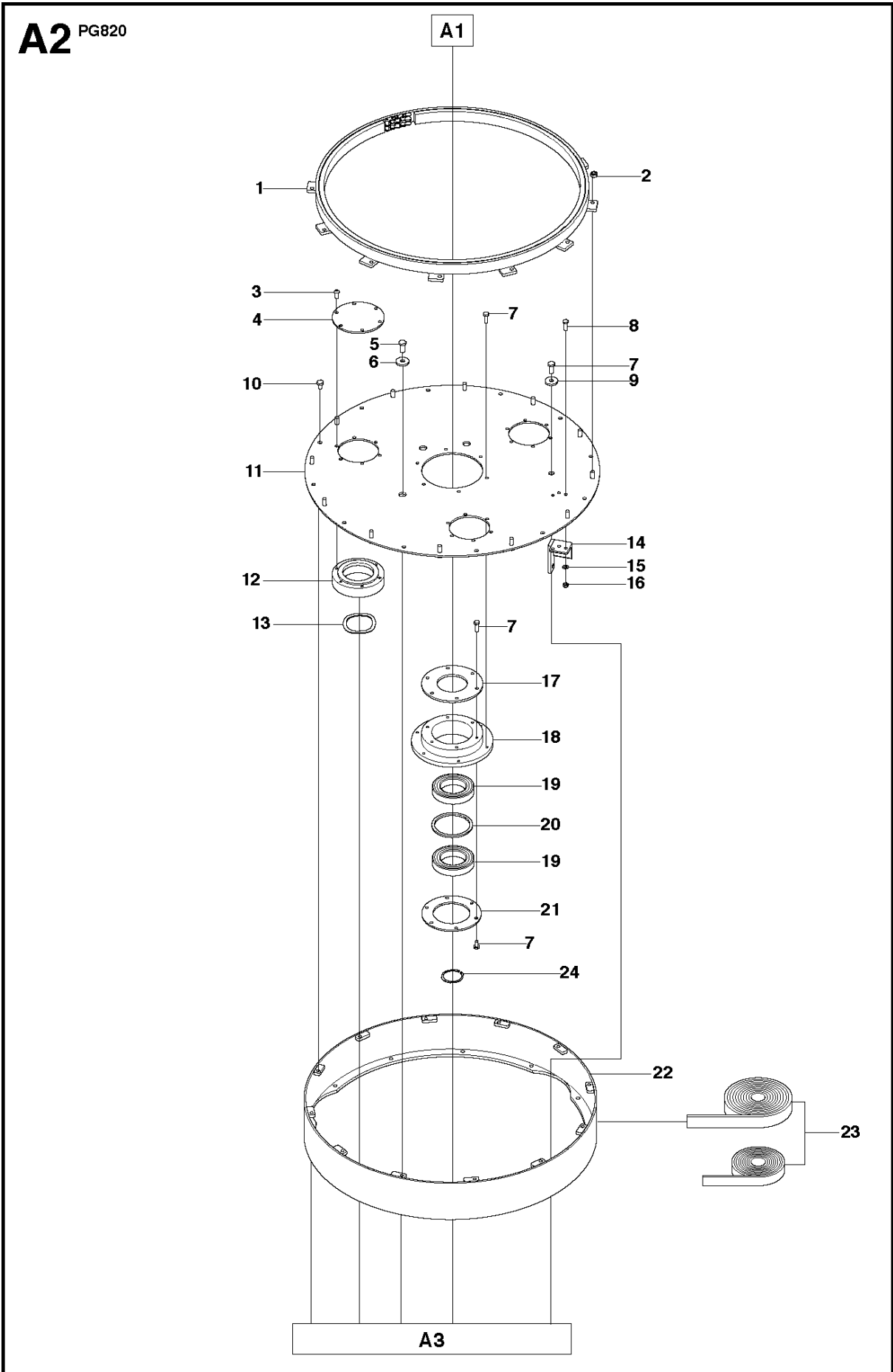

GRINDER

PG 820, To machine 0904-1 and forward, 2009-07

Ref	Part No	Description	Remark	QTY KIT
1	502 53 86-01	CHAIN RING		1
2	732 25 20-01	HEXAGON LOCKING NUT		12
3	504 75 02-01	SCREW IHANM		18
4	502 53 79-01	COVER PLATE		3
5	725 25 34-71	SCREW EHHM		3
6	504 72 95-01	WASHER		3
7	725 24 51-76	SCREW EHHM		19
8	725 24 53-76	SCREW EHHM		3
9	543 04 66-47	WASHER		1
10	725 24 89-76	SCREW EHHM		12
11	502 53 74-01	TOP PLATE		1
12	502 53 71-01	BEARING HOUSING		3
13	502 53 99-01	WAVE WASHER		3
14	504 72 99-01	STRUT		1
15	734 11 63-01	WASHER		3
16	732 25 18-01	HEXAGON LOCKING NUT		3
17	504 72 82-01	PLATE		1
18	502 53 72-01	BEARING HOUSING		1
19	502 53 89-01	BALL BEARING		2
20	504 72 88-01	SPACER		1
21	504 72 81-01	PLATE		1
22	502 53 83-01	RIM		1
23	502 53 48-01	PLANETARY SEAL RUBBER		1
24	502 53 90-01	CIRCLIP		1

A1 PG820

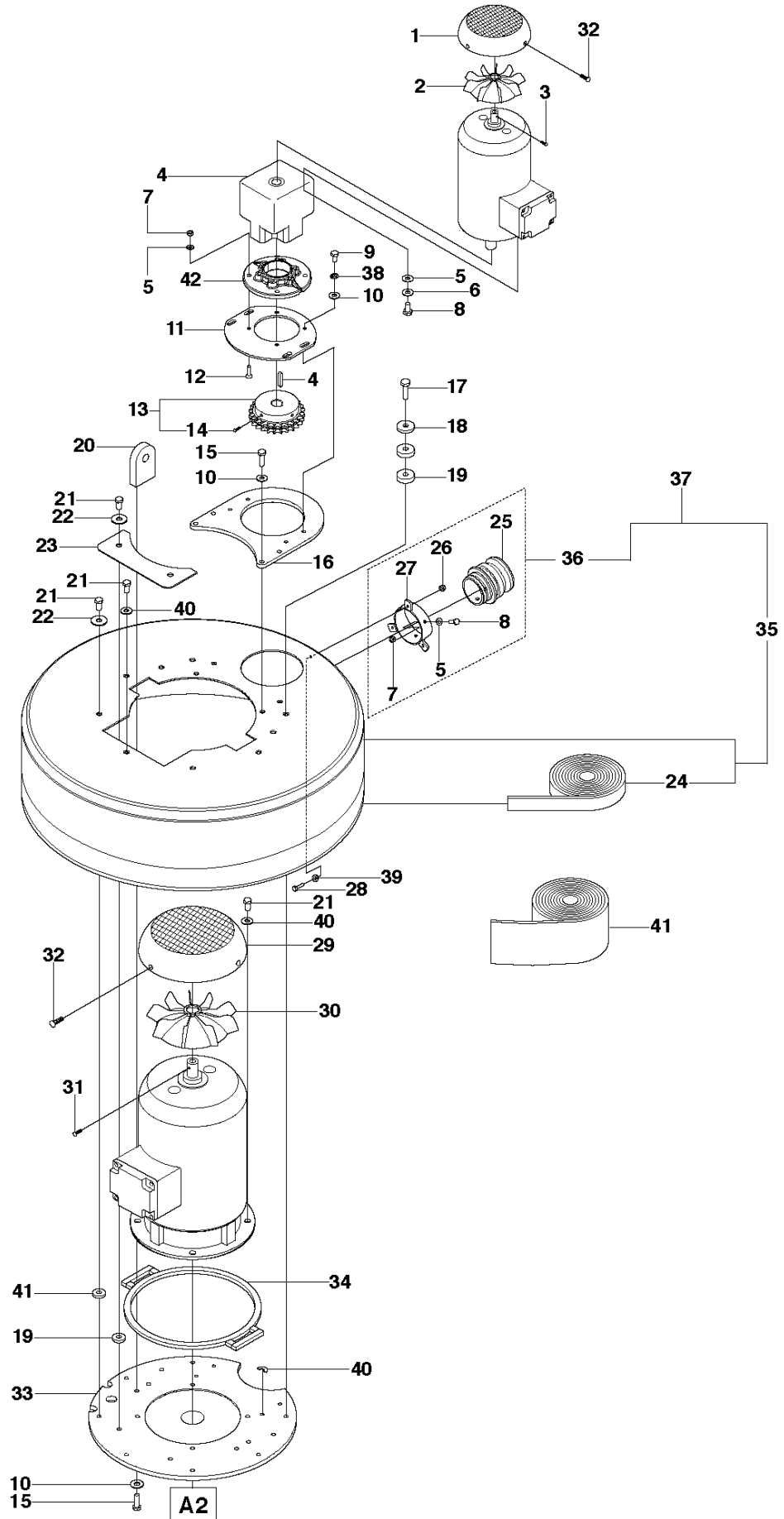

GRINDER

PG 820, To machine 0904-1 and forward, 2009-07

Ref	Part No	Description	Remark	QTY	KIT
1	516 05 68-01	COVER		1	
2	516 05 70-01	FAN		1	
3	516 05 71-01	PIN		1	
4	580 99 98-01	GEAR BOX ASSY		1	
5	734 11 63-01	WASHER		10	36
6	735 11 64-01	SPRING WASHER		4	
7	732 25 18-01	HEXAGON LOCKING NUT		6	36
8	725 24 53-76	SCREW EHHM		6	36
9	725 24 91-76	SCREW EHHM		4	
10	734 11 72-01	WASHER		12	
11	502 53 81-01	PLATE		1	
12	725 64 53-51	SCREW IHCSFM		4	
13	502 54 24-01	DRIVE SPROCKET ASSY		1	
14	728 54 51-05	SCREW IHSETM		2	13
15	725 24 97-71	SCREW EHHM		6	
16	502 55 15-01	BRACKET		1	
17	725 25 02-51	SCREW EHHM		2	
18	504 72 63-04	WASHER		11	
19	504 72 63-03	WASHER		4	
20	504 72 90-01	LIFTING LUG		2	
21	725 25 34-71	SCREW EHHM		13	
22	734 11 78-01	WASHER		5	
23	504 72 93-01	COVER PLATE		1	
24	504 72 95-01	WASHER		2	
25	504 72 98-02	COUPLING		1	36
26	732 25 16-01	HEXAGON LOCKING NUT		3	36
27	522 44 83-01	BRACKET		1	36
28	724 33 70-51	SCREW CRCSFM		3	
29	516 05 72-01	COVER		1	
30	516 05 73-01	FAN		1	
31	516 05 74-01	PIN		1	
32	723 13 20-51	SCREW SLCHM		7	
33	502 55 11-01	PLATE		1	
34	516 05 78-02	SEAL		1	
35	502 53 85-01	VELCRO		1	37
36	522 44 82-01	PORT		1	37
37	522 44 81-01	COVER CMPL.		1	
38	735 11 73-01	SPRING WASHER		4	
39	504 74 83-01	WASHER		8	
40	504 74 73-01	WASHER		2	
41	502 54 86-01	SKIRT		1	
42	587 04 09-01	MOUNTING PLATE		1	

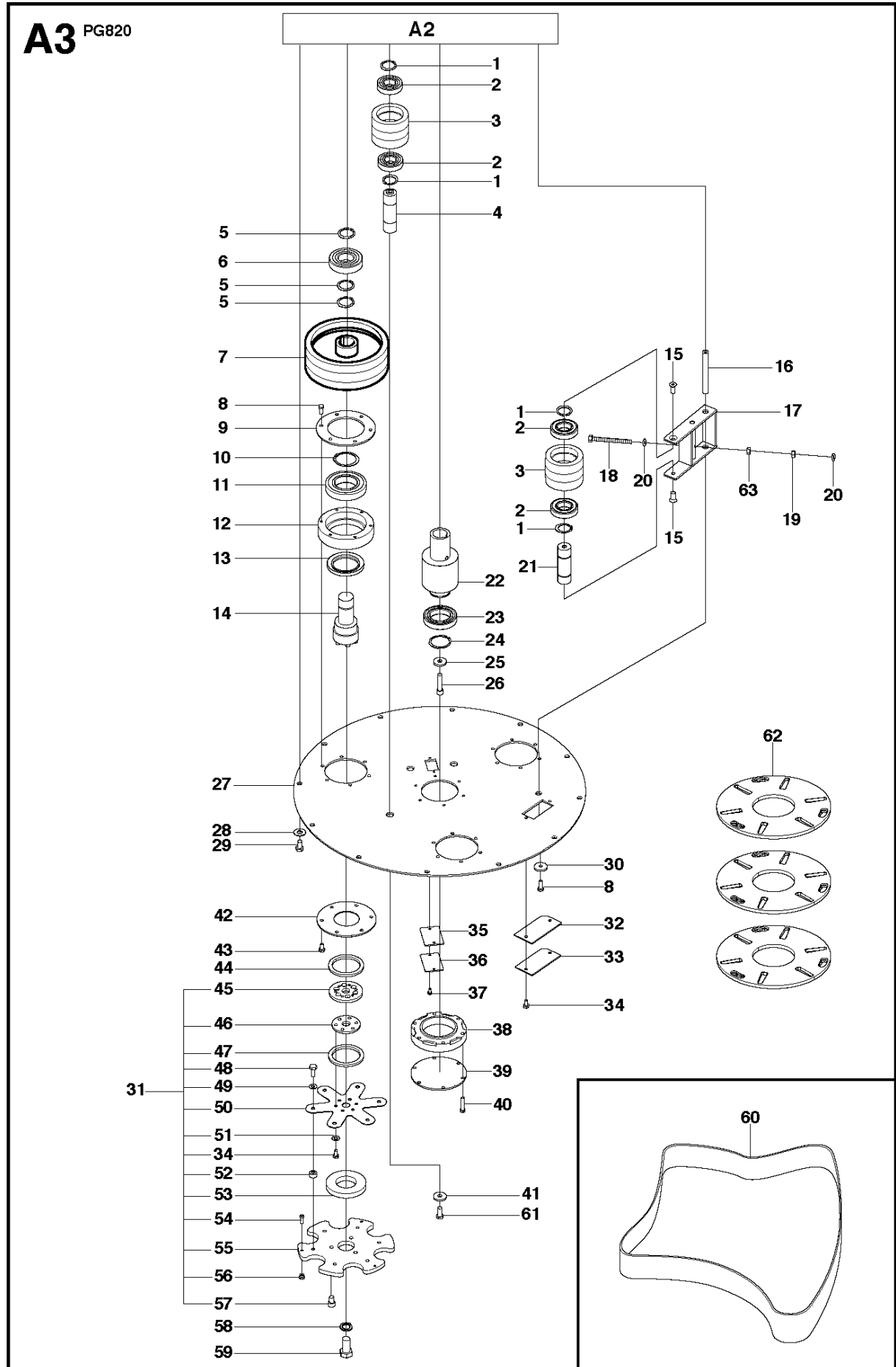

GRINDER

PG 820, To machine 0904-1 and forward, 2009-07

Ref	Part No	Description	Remark	QTY	KIT
1	735 31 33-00	CIRCLIP		8	
2	502 53 91-01	BALL BEARING		8	
3	502 53 68-01	PULLEY		4	
4	502 53 67-01	SHAFT		3	
5	735 31 37-00	CIRCLIP		9	
6	502 53 93-01	BALL BEARING		3	
7	502 53 64-01	PULLEY		3	
8	725 24 51-76	SCREW EHHM		19	
9	502 53 77-01	PLATE		3	
10	502 53 96-01	CIRCLIP		3	
11	502 53 95-01	BALL BEARING		3	
12	502 53 70-01	BEARING HOUSING		3	
13	502 53 97-01	RADIAL SEAL		3	
14	502 53 66-01	PULLEY SHAFT		3	
15	725 64 93-51	SCREW IHCSFM		2	
16	516 05 81-01	SHAFT		1	
17	502 53 82-01	FRAME		1	
18	725 25 15-71	SCREW EHHM		1	
19	731 23 20-01	HEXAGON NUT		1	
20	734 11 72-01	WASHER		2	
21	502 53 69-01	SHAFT		1	
22	502 53 65-01	PULLEY		1	
23	502 53 87-01	BALL BEARING		1	
24	502 53 88-01	CIRCLIP		1	
25	504 72 63-03	WASHER		1	
26	504 74 88-01	SCREW IHSCM		1	
27	502 53 75-01	BOTTOM PLATE		1	
28	734 11 78-01	WASHER		12	
29	725 25 32-71	SCREW EHHM		12	
30	543 04 66-47	WASHER		1	
31	502 53 40-01	SPRING STEEL SYSTEM		3	
32	516 05 84-01	SEAL		1	
33	504 72 78-01	COVER PLATE		1	
34	725 24 49-76	SCREW EHHM		20	
35	516 05 85-01	SEAL		1	
36	504 72 79-01	COVER PLATE		1	
37	725 23 66-71	SCREW EHHM		2	
38	502 53 73-01	BEARING HOUSING		1	
39	502 53 78-01	COVER PLATE		1	
40	725 24 60-81	SCREW EHHM		6	
41	504 72 95-01	WASHER		3	
42	504 72 80-01	COVER PLATE		3	
43	725 24 53-76	SCREW EHHM		18	
44	502 53 98-01	SEAL		3	
45	502 53 40-06	HUB		3	31
46	502 53 40-04	SPACER PLATE		3	31
47	502 53 40-05	RUBBER RING		3	31
48	725 24 93-76	SCREW EHHM		18	31
49	734 11 72-01	WASHER		18	31
50	502 53 42-01	SPRING PLATE		3	31
51	734 11 63-01	WASHER		18	31
52	502 53 40-14	SPACER		18	31
53	502 53 43-01	RING		3	31
54	725 53 70-51	SCREW IHSCM		9	31
55	502 53 40-02	PLATE		3	31
56	502 53 44-01	LOCK		9	31
57	504 74 84-01	SCREW IHSCM		9	31
58	504 74 96-03	LOCK WASHER		3	
59	504 74 89-01	SCREW EHHM		3	
60	502 54 23-01	DRIVE BELT		1	
61	725 25 34-71	SCREW EHHM		3	
62	502 53 22-01	HOLDER DISC		3	
63	732 25 20-01	HEXAGON LOCKING NUT		1	